

FR MONTAGE DU LUSTRE *TOURAH SMALL*

1. Passez les fils dans le manchon A (10cm de long).
2. Vissez le manchon A dans le trou fileté de la *nourrice*.
3. Glissez le tube B dans le manchon A en faisant suivre les fils électriques. Pour diminuer la hauteur de votre lustre, le tube B peut être raccourci au moyen d'une petite scie à métaux.
4. Ajustez la hauteur du lustre en serrant la petite vis du manchon A à l'aide de la clé allen qui vous est fournie.
5. Fixez le tube B sur le boîtier C et serrez le tout.
6. Fixez la patère D au plafond et raccordez le fil de terre à la connexion prévue.
7. Raccordez votre arrivée de courant aux connexions électriques du lustre et fixez le boîtier C sur la patère D à l'aide des deux vis latérales.

NL MONTAGE VAN DE LUSTER *TOURAH SMALL*

1. Glij de draden door buis A (10cm lang).
2. Schroef buis A in de voorziene schroefdraad van de *nourrice*.
3. Schuif buis B in buis A en laat de elektrische draden volgen. Om de hoogte van de luster te verminderen kan de buis B dmv een klein metaalzaag ingekort worden.
4. Stel de hoogte van de luster in door middel van het vastdraaien van het schroefje van de buis A, met behulp van een inbussleutel die werd meegeleverd.
5. Bevestig de buis B aan basis C en draai alles vast.
6. Bevestig de bevestigingsdoos D tegen het plafond en bevestig de aardingdraad aan de voorziene aansluiting.
7. Verbind de stroomtoegang aan de elektrische aansluitingen van de luster en bevestig basis C op de bevestigingsdoos D met behulp van de 2 zijschroeven.

EN MOUNTING OF THE LUSTER *TOURAH SMALL*

1. Slide the wires through tube A (10 cm long).
2. Screw tube A in the provided screw thread in the *nourrice*.
3. Slide the tube B into the tube A and let following the electric wires. To reduce the height of the luster, tube B can be shortened by means of a small hacksaw.
4. Set the height of the suspension by tightening the small screw of the tube A, using the included allen key.
5. Attach tube B on the base C and tighten everything.
6. Attach the ceiling box D against the ceiling and connect the earth wire to the provided connection on the ceiling box.
7. Connect the power access to the electrical connections of the luster and attach base C to the ceiling box D, using the lateral screws.

DE MONTAGE DER LEUCHTER *TOURAH SMALL*

1. Schieben Sie die Drähte durch Rohr A (10 cm lang).
2. Schrauben Sie Rohr A in das mitgelieferte Schraubengewinde von die *Nourrice*.
3. Schieben Sie das Rohr B in das Rohr A, und lassen Sie die elektrischen Leitungen folgen. Um die Leuchter in der Höhe zu verstellen, können Sie Rohr B mittels einer kleinen Metallsäge einkürzen.
4. Stellen Sie die Höhe von der Leuchter ein durch leichte Befestigung von den Schraube von Rohr A, mit dem mitgelieferten Inbusschlüssel.
5. Befestigen Sie Rohr B an der Basis C und ziehen Sie alles.
6. Befestigen Sie die Montageplatte D an der Decke und schließen Sie die Erdung an die zur Verfügung gestellte Verbindung an der Montageplatte an.
7. Schließen Sie die elektrische Zuleitung an die elektrischen Anschlüsse der Leuchter an und fixieren Sie die Basis C auf der Montageplatte D mit den seitlichen Schrauben.

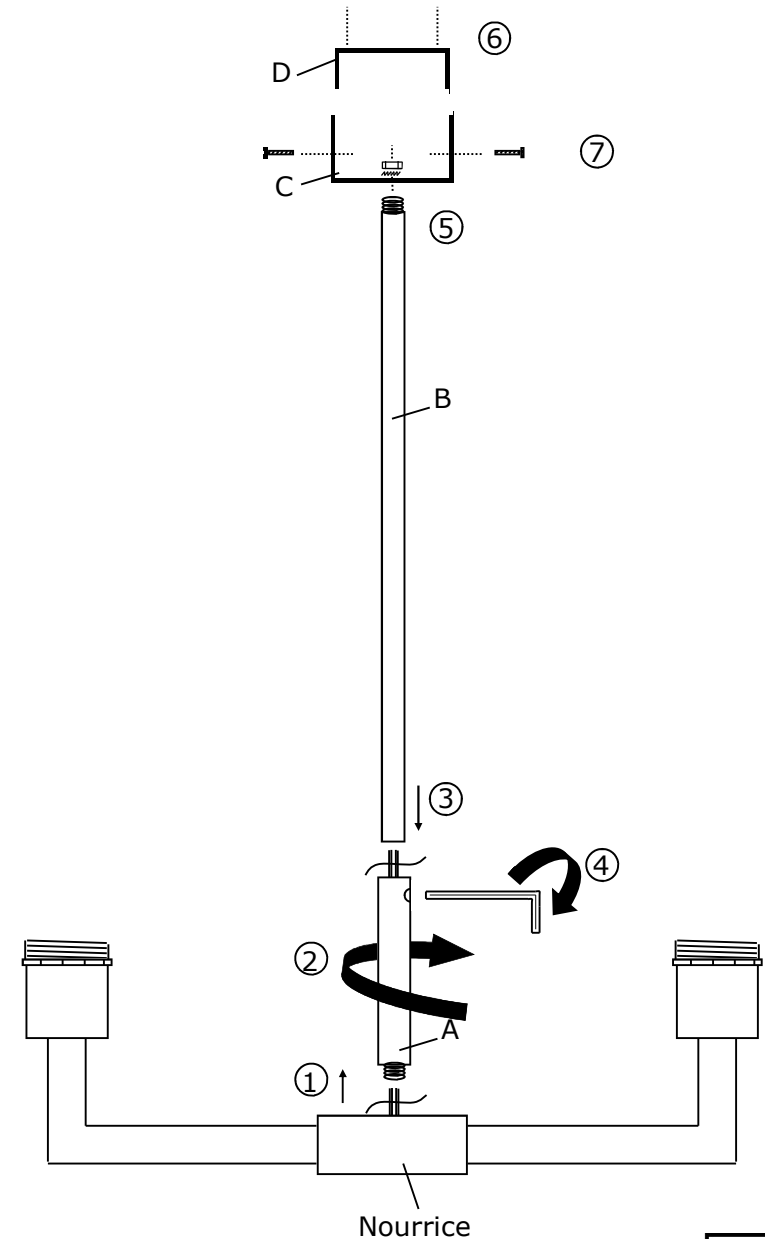

TOURAH SMALL





Manufacturer : DAVIDTS LIGHTING – Brussels – Belgium – www.davidts.com

Installation and security instructions (please read and save)

This luminaire is manufactured according to European directives and standards relating to quality and safety of lighting fixtures. A declaration of conformity is available by downloading on our site.

Description of the lighting

Lighting for fixing to the wall or ceiling with handmade shade(s) with a soft and pleasant light distribution. More pictures, drawings and complete descriptions are available on our website.

Environmental protection

Our packaging is made from 100% recyclable or re-usable material. For care of the environment please sort or recycle. Fluorescent bulbs and waste electrical equipment should not be disposed of with household waste please take to a recycling facility. This fixture is essentially composed of solid brass. This metal and other elements are fully recyclable. At end of life, if you take the fixture to a recycling facility, each metal will be recovered for new metal production.

Installation of the lighting

This lighting is only intended for indoor use, it must be installed away from moisture, splashing and sources of heat. Suitable for direct mounting on normally flammable surfaces. Before starting the installation, ensure the electrical supply is OFF at the circuit breaker in the consumer unit. Only switching OFF at the wall switch is not adequate.

Carefully remove all packaging. All of our fixtures are fixed to the wall or to the ceiling by means of a mounting plate (placement is done by means of screws and dowels, not supplied). Some of our luminaires have more detailed installation instructions (attached to this document). Please read carefully before starting the installation.

If your light lighting has a fitting with shade ring, unscrew it in order to secure the shade to the fitting. If the shade is made with a seam, make sure that it is positioned towards the back of the light. Screw down the ring carefully. Place the bulb (not supplied) without forcing into the fitting. If necessary straighten the shade, only by carefully flexing the metal rods of the shade.

If you have any doubt about the installation of this lighting, please contact a qualified electrician.

Inserting or replacing a bulb

Always ensure the electrical supply is OFF before this operation. If necessary, let the old bulb to cool for 10 minutes before removing. Place the bulb without forcing into the fitting. Do not directly touch it with the fingers, but with a cloth (fingerprints reduce the lifetime of a bulb). Be always attentive to the choice of a bulb, never exceed the maximum power (W) authorized, indicated on the labels of the light fitting. If an integral LED bulb attached to the fixture is defective, please contact your distributor.

Maintenance of your shades

When your shade is dusted use only a brush suitable for delicate fabrics. Never rub the shade with a damp cloth or with water. Stains or marks on shades can't be removed, attempting removal will risk increasing the surface of the stain. In the case of a disaster, only a new shade can recover the original beautiful aspect and clarity of your lighting. To do this please contact your distributor.

Maintenance of your lighting

Because smoke and dust particles in the air are attracted by a heat source, a deposit will appear on the fixture in the course of time. For maintenance, allow the bulb to cool for at least 10 minutes. Clean the fixture with a paper towel soaked with glass cleaner. Never use solvents, abrasive or corrosive products. Never immerse the fixture in water. If the wires are damaged, they must be replaced by a qualified electrician. This fixture must never be modified as this can make it dangerous to use.