

### FR PLACEMENT de l'abat-jour ABOUSIR

1. Sur l'arrière de l'abat-jour se trouve une barrette **A** de 36cm (haut) et deux œillets **B** (bas).
2. Pour placer l'abat-jour sur l'applique, basculez votre abat-jour et faites passer la barrette à l'arrière de la grande plaque.
3. Ensuite, laissez retomber l'abat-jour. La barrette se déposera sur le boîtier mural et les œillets se placeront sur l'avant de la plaque. Votre abat-jour sera correctement placé.

### NL PLAATSING van de ABOUSIR lampenkap

1. Op de achterkant van de lampenkap bevindt zich een staaf **A** van 36cm (boven) en 2 oogjes **B** (onder).
2. Om de lampenkap op de wandlamp te plaatsen, tuimel uw lampenkap en passeer de staaf aan de achterkant van de grote plaat.
3. Laat dan uw lampenkap terugvallen. De staaf zal zich plaatsen op de murale basis en oogjes plaatsen zich aan de voorzijde van de plaat. Uw lampenkap zal perfect geplaatst zijn.

### EN PLACEMENT of the ABOUSIR lampshade

1. On the back of the lampshade is a rod of 36cm **A** (top) and 2 eyelets **B** (below).
2. In order to place the lampshade on the wall lamp, toggle your lampshade and place the rod behind the large plate.
3. Let fall the lampshade back. The rod will place himself on the wall box and the eyelets will rest on the front of the plate. Your lampshade will be perfectly placed.

### DE PLATZIERUNG der ABOUSIR Lampenschirm

1. Auf der Rückseite der Lampenschirm ist ein Stab von 36 cm **A** (oben) und 2 Ösen **B** (unten).
2. Um der Lampenschirm zu installieren auf die Wandleuchte, schalten sie Ihren Lampenschirm und lassen Sie der Stab an der Rückseite der großen Platte passerern.
3. Lassen Sie die Lampenschirm zurück fallen. Der Stab stellt sich auf der Wandbasis und die Ösen an der Vorderseite der großen Platte. Der Lampenschirm wird perfekt platziert.

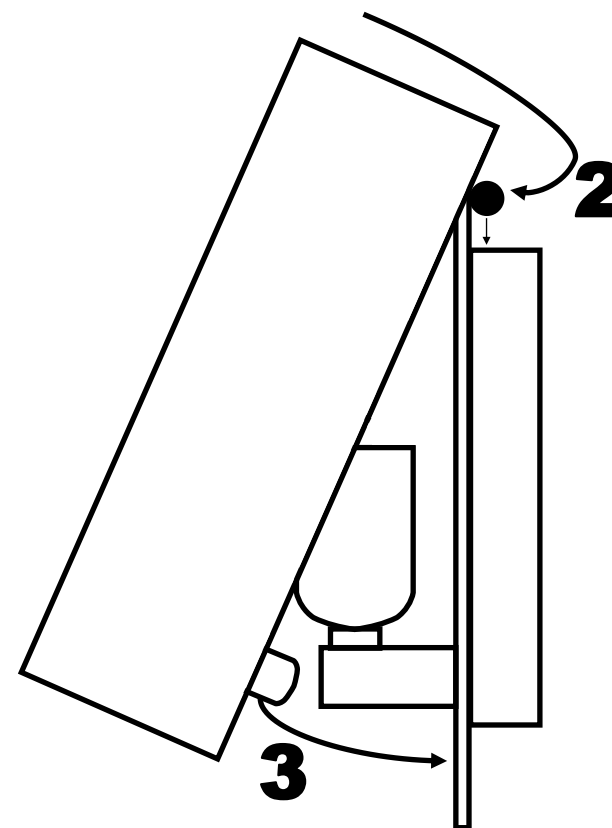
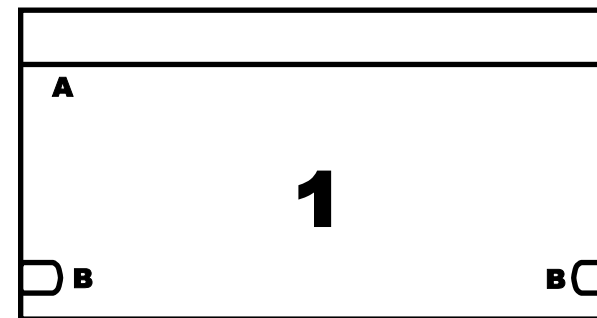

# ABOUSIR





**Manufacturer : DAVIDTS LIGHTING – Brussels – Belgium – [www.davidts.com](http://www.davidts.com)**

### **Installation and security instructions (please read and save)**

This luminaire is manufactured according to European directives and standards relating to quality and safety of lighting fixtures. A declaration of conformity is available by downloading on our site.

### **Description of the lighting**

Lighting for fixing to the wall or ceiling with handmade lampshade(s) with a soft and pleasant light distribution. More pictures, drawings and complete descriptions are available on our website.

### **Environmental protection**

Our packaging is made from 100% recyclable or re-usable material. For care of the environment please sort or recycle. Fluorescent bulbs and waste electrical equipment should not be disposed of with household waste please take to a recycling facility. This fixture is essentially composed of solid brass. This metal and other elements are fully recyclable. At end of life, if you take the fixture to a recycling facility, each metal will be recovered for new metal production.

### **Installation of the lighting**

This lighting is only intended for indoor use, it must be installed away from moisture, splashing and sources of heat. Suitable for direct mounting on normally flammable surfaces. Before starting the installation, ensure the electrical supply is OFF at the circuit breaker in the consumer unit. Only switching OFF at the wall switch is not adequate.

Carefully remove all packaging. All of our fixtures are fixed to the wall or to the ceiling by means of a mounting plate (placement is done by means of screws and dowels, not supplied). Some of our luminaires have more detailed installation instructions (attached to this document). Please read carefully before starting the installation.

If your light lighting has a fitting with lampshade ring, unscrew it in order to secure the lampshade to the fitting. If the lampshade is made with a seam, make sure that it is positioned towards the back of the light. Screw down the ring carefully. Place the bulb (not supplied) without forcing into the fitting. If necessary straighten the lampshade, only by carefully flexing the metal rods of the lampshade.

If you have any doubt about the installation of this lighting, please contact a qualified electrician.

### **Inserting or replacing a bulb**

Always ensure the electrical supply is OFF before this operation. If necessary, let the old bulb to cool for 10 minutes before removing. Place the bulb without forcing into the fitting. Do not directly touch it with the fingers, but with a cloth (fingerprints reduce the lifetime of a bulb). Be always attentive to the choice of a bulb, never exceed the maximum power (W) authorized, indicated on the labels of the light fitting. If an integral LED bulb attached to the fixture is defective, please contact your distributor.

### **Maintenance of your lampshades**

When your lampshade is dusted use only a brush suitable for delicate fabrics. Never rub the lampshade with a damp cloth or with water. Stains or marks on lampshades can't be removed, attempting removal will risk increasing the surface of the stain. In the case of a disaster, only a new lampshade can recover the original beautiful aspect and clarity of your lighting. To do this please contact your distributor.

### **Maintenance of your lighting**

Because smoke and dust particles in the air are attracted by a heat source, a deposit will appear on the fixture in the course of time. For maintenance, allow the bulb to cool for at least 10 minutes. Clean the fixture with a paper towel soaked with glass cleaner. Never use solvents, abrasive or corrosive products. Never immerse the fixture in water. If the wires are damaged, they must be replaced by a qualified electrician. This fixture must never be modified as this can make it dangerous to use.