

## FR MONTAGE DE LA SUSPENSION *GEMINI*

1. Passez les fils dans un des tubes A.
2. Vissez ce tube dans le trou fileté de la suspente carrée.
3. Glissez le tube B dans le tube A en faisant suivre les fils électriques. Répétez l'opération pour l'autre côté. Pour diminuer la hauteur de la suspension, les tubes B peuvent être raccourcis au moyen d'une petite scie à métaux.
4. Ajustez la hauteur de la suspension en serrant la petite vis du tube A à l'aide de la clé allen qui vous est fournie.
5. Fixez les tubes B sur le boîtier C à l'aide des rondelles éventails, des écrous hexagonaux et d'une clé ronde de 13mm.
6. Fixez la patère de fixation D au plafond et raccordez le fil de terre à la connexion prévue sur la patère.
7. Raccordez votre arrivée de courant aux connexions électriques de la suspension et fixez le boîtier C sur la patère de fixation D à l'aide des vis latérales.

## NL MONTAGE VAN DE HANGLAMP *GEMINI*

1. Glij de draden door één van de buizen A.
2. Schroef buis A in de voorziene schroefdraad aan de vierkante zwevende basis.
3. Glijd de buis B in buis A en laat de elektrische draden volgen. Herhaal deze operatie aan de andere zijde. Om de hoogte van de hanglamp te verminderen kunnen de buizen B dmv een klein metaalzaagje ingekort worden.
4. Stel de hoogte van de hanglamp in door middel van het schroefje van buis A vast te draaien met behulp van de inbussleutel die werd meegeleverd.
5. Bevestig de buizen B aan doos C met behulp van de growers, de hexagonale moeren en met een ronde sleutel van 13mm.
6. Bevestig de fixatieplaat D tegen het plafond en verbind de aardingsdraad aan de voorziene bevestiging op de fixatieplaat.
7. Verbind de stroomtoegang aan de elektrische aansluitingen van de hanglamp en bevestig doos C aan de fixatieplaat D met behulp van de zijschroeven.

## EN MOUNTING OF THE SUSPENSION *GEMINI*

1. Slide the wires through one of the tubes A.
2. Screw tube A in the provided screw thread to the square floating basis.
3. Slide tube B in tube A and let following the electric wires. Repeat this operation on the other side. To reduce the height of the suspension, the tubes B can be shortened by means of a small hacksaw.
4. Set the height of the suspension by tightening the screws of the tubes A, using the included allen key.
5. Attach the tubes B to box C, using the growers and the hexagonal screws, and fix everything with a 13mm round key.
6. Attach the ceiling plate D against the ceiling and connect the earth wire to the provided connection on the ceiling plate.
7. Connect the power access to the electrical connections of the suspension and attach box C to the ceiling plate D, using the lateral screws.

## DE MONTAGE DER PENDELLEUCHE *GEMINI*

1. Schieben Sie die Drähte durch eine der Rohre A.
2. Schrauben Sie die beiden Rohre A in die Gewindebohrungen von der eckigen hängenden Basis.
3. Schieben Sie das Rohr B in das Rohr A, und lassen Sie die elektrischen Leitungen folgen. Wiederholen Sie diesen Vorgang auf der anderen Seite. Um die Pendelleuchte in der Höhe zu verstellen, können Sie der Rohre B mittels einer kleinen Metallsäge einkürzen.
4. Stellen Sie die Höhe von der Pendelleuchte ein durch leichte Befestigung von den Schrauben von den Rohren A, mit dem mitgelieferten Inbusschlüssel.
5. Befestigen Sie die Rohre B an der Basis C mit den Unterlegscheiben, die Sechskantschrauben und mit einem runden 13mm Schlüssel.
6. Befestigen Sie die Montageplatte D an der Decke und schließen Sie die Erdung an die zur Verfügung gestellte Verbindung an der Montageplatte an.
7. Schließen Sie die elektrische Zuleitung an die elektrischen Anschlüsse der Pendelleuchte an und fixieren Sie die Basis C auf der Montageplatte D mit den seitlichen Schrauben.

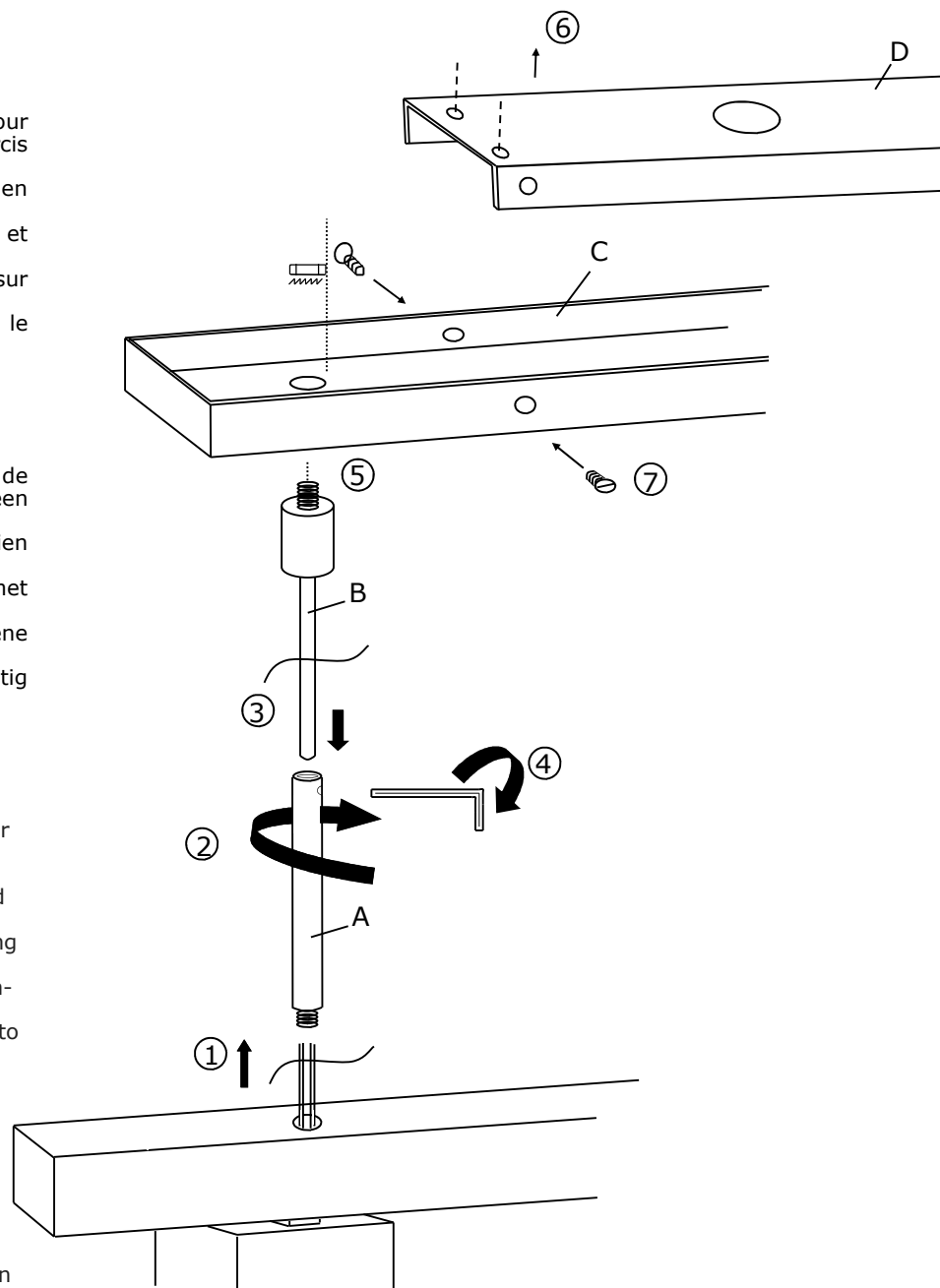

# GEMINI





Manufacturer : DAVIDTS LIGHTING – Brussels – Belgium – [www.davidts.com](http://www.davidts.com)

## **Installation and security instructions (please read and save)**

This luminaire is manufactured according to European directives and standards relating to quality and safety of lighting fixtures. A declaration of conformity is available by downloading on our site.

### **Description of the lighting**

Lighting for fixing to the wall or ceiling. More pictures, drawings and complete descriptions are available on our website.

### **Environmental protection**

Our packaging is made from 100% recyclable or re-usable material. For care of the environment please sort or recycle. Fluorescent bulbs and waste electrical equipment should not be disposed of with household waste please take to a recycling facility. This fixture is essentially composed of solid brass. This metal and other elements are fully recyclable. At end of life, if you take the fixture to a recycling facility, each metal will be recovered for new metal production.

### **Installation of the lighting**

This lighting is only intended for indoor use, it must be installed away from moisture, splashing and sources of heat. Suitable for direct mounting on normally flammable surfaces. Before starting the installation, ensure the electrical supply is OFF at the circuit breaker in the consumer unit. Only switching OFF at the wall switch is not adequate. Carefully remove all packaging. All of our fixtures are fixed to the wall or to the ceiling by means of a mounting plate (placement is done by means of screws and dowels, not supplied). Some of our luminaires have more detailed installation instructions (attached to this document). Please read carefully before starting the installation. If you have any doubt about the installation of this lighting, please contact a qualified electrician.

### **Inserting or replacing a bulb**

Always ensure the electrical supply is OFF before this operation. If necessary, let the old bulb to cool for 10 minutes before removing. Place the bulb without forcing into the fitting. Do not directly touch it with the fingers, but with a cloth (fingerprints reduce the lifetime of a bulb). Be always attentive to the choice of a bulb, never exceed the maximum power (W) authorized, indicated on the labels of the light fitting. If an integral LED bulb attached to the fixture is defective, please contact your distributor.

### **Maintenance of your lighting**

Because smoke and dust particles in the air are attracted by a heat source, a deposit will appear on the fixture in the course of time. For maintenance, allow the bulb to cool for at least 10 minutes. Clean the fixture with a paper towel soaked with glass cleaner. Never use solvents, abrasive or corrosive products. Never immerse the fixture in water. If the wires are damaged, they must be replaced by a qualified electrician. This fixture must never be modified as this can make it dangerous to use.